

TTV-410X Family of Thermal Test Vehicles

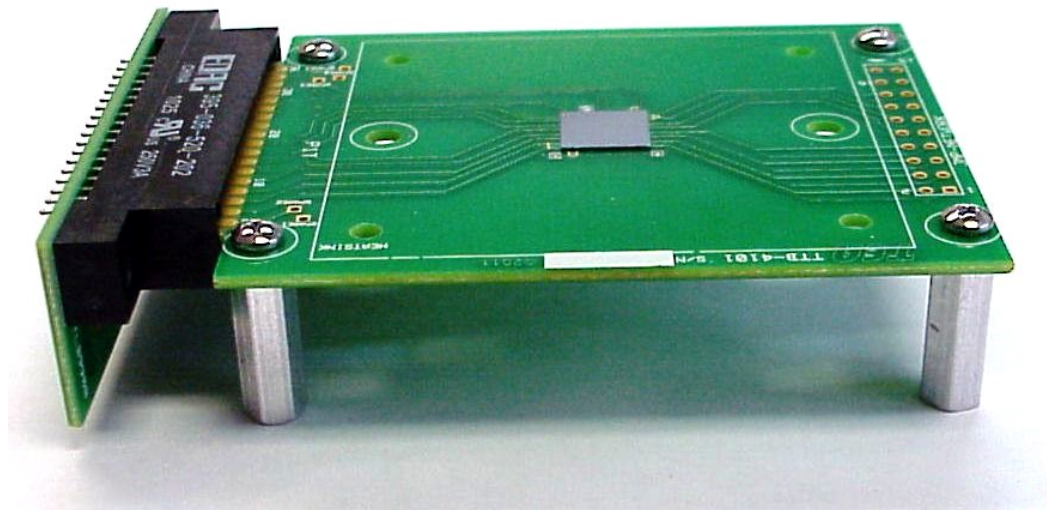

Application Manual

Thermal Engineering Associates, Inc.

3287 Kifer Road, Santa Clara, CA 95051 USA

Tel: 650-961-5900 Email: info@thermengr.com

TTV-410X Family Product Configurations

(Pictures shown below are of the TTV-4101 but are generally applicable to other versions.)

TTV-410X Board

TTV-4101-0-000

(4X4 Array, 10.23X10.23mm)

TTV-4102-0-000

(5X5 Array, 12.8X12.8mm)

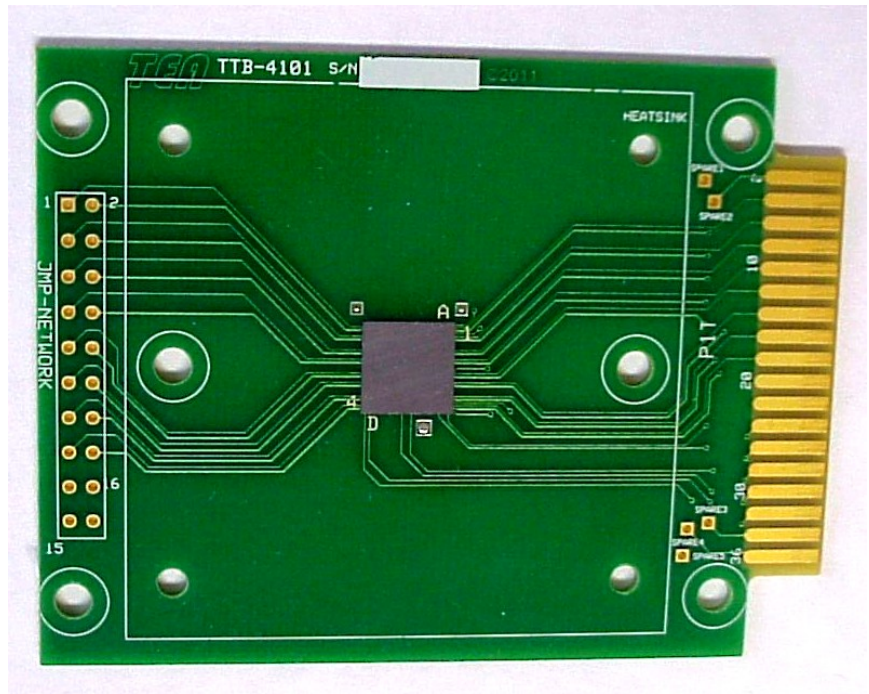

TTV-410X Board with Mating Connector and Breakout Board

TTV-4101-?-000

(4X4 Array, 10.23X10.23mm)

TTV-4102-?-000

(5X5 Array, 12.8X12.8mm)

? = 1 for 105°C connector
? = 2 for 130°C connector
? = 3 for 105°C edge finger & 5-diode ribbon cable connectors

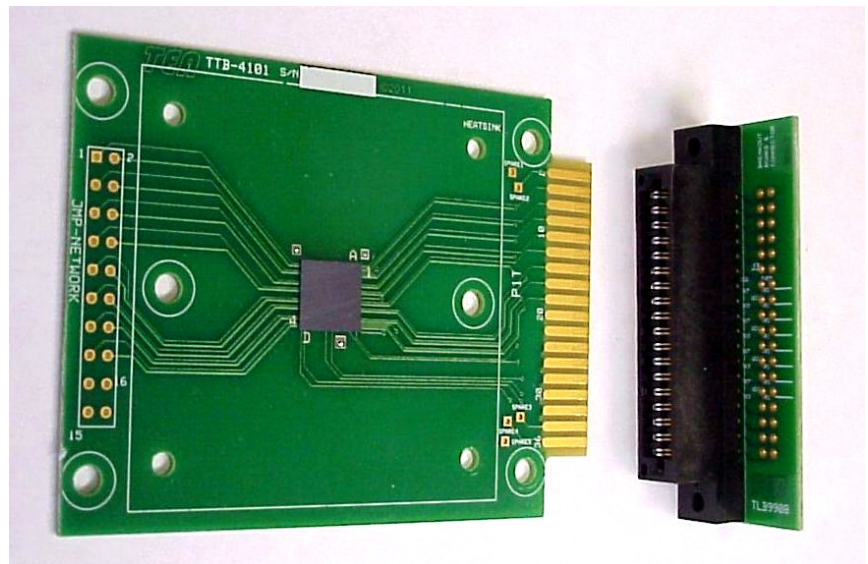

Notes:

- 1) The Jumper Network solder eyelets shown on the left in the pictures above can be used to electrically reconfigure the heating resistors – see schematics for the board electrical connections.
- 2) The Breakout Board/Connector combination can be used with either the board up or down position relative to the edge finger connectors.
- 3) Refer to the TTC-1002 Applications Manual for further information on the chips. Manual is available upon request from TEA.

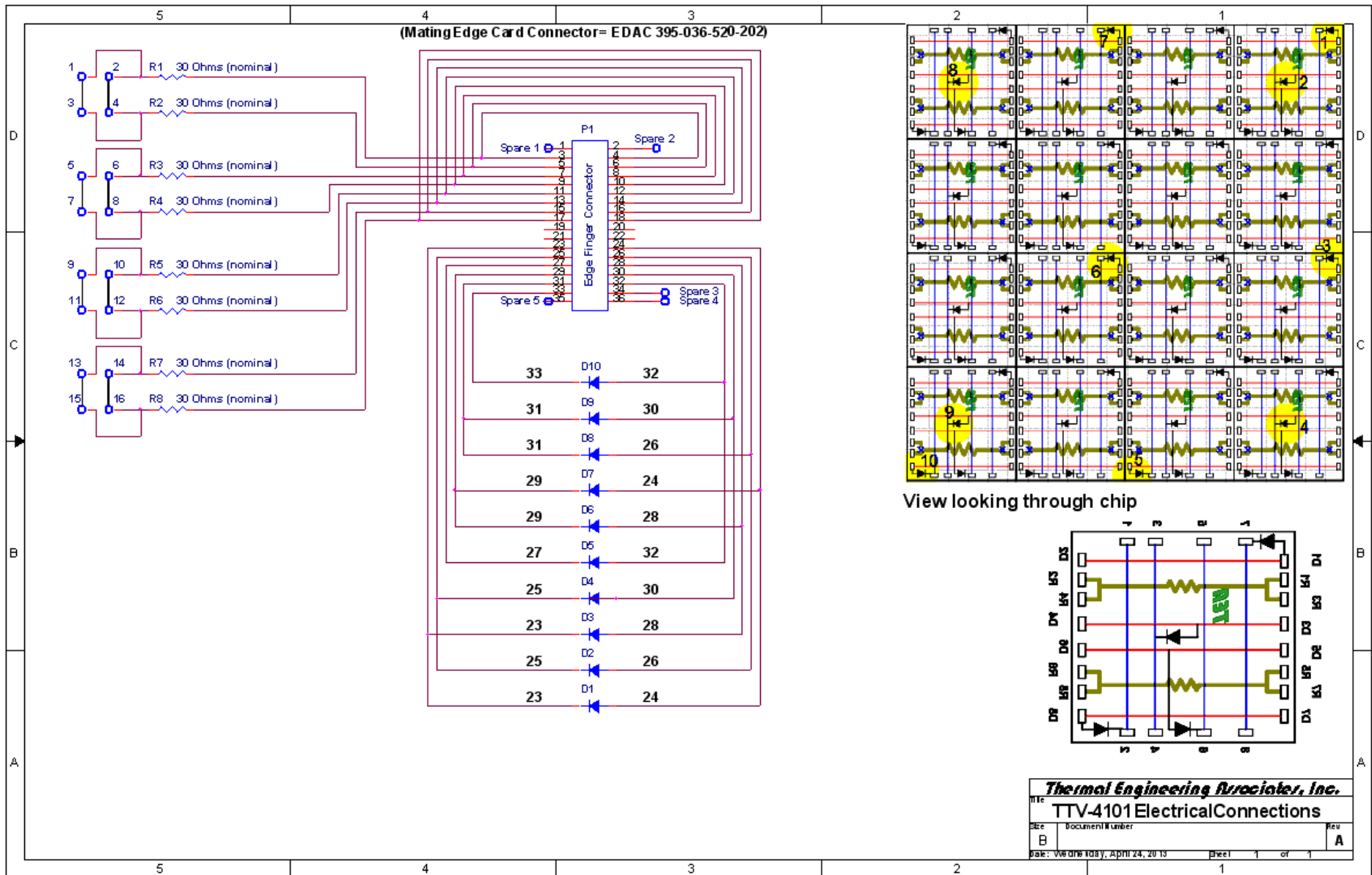

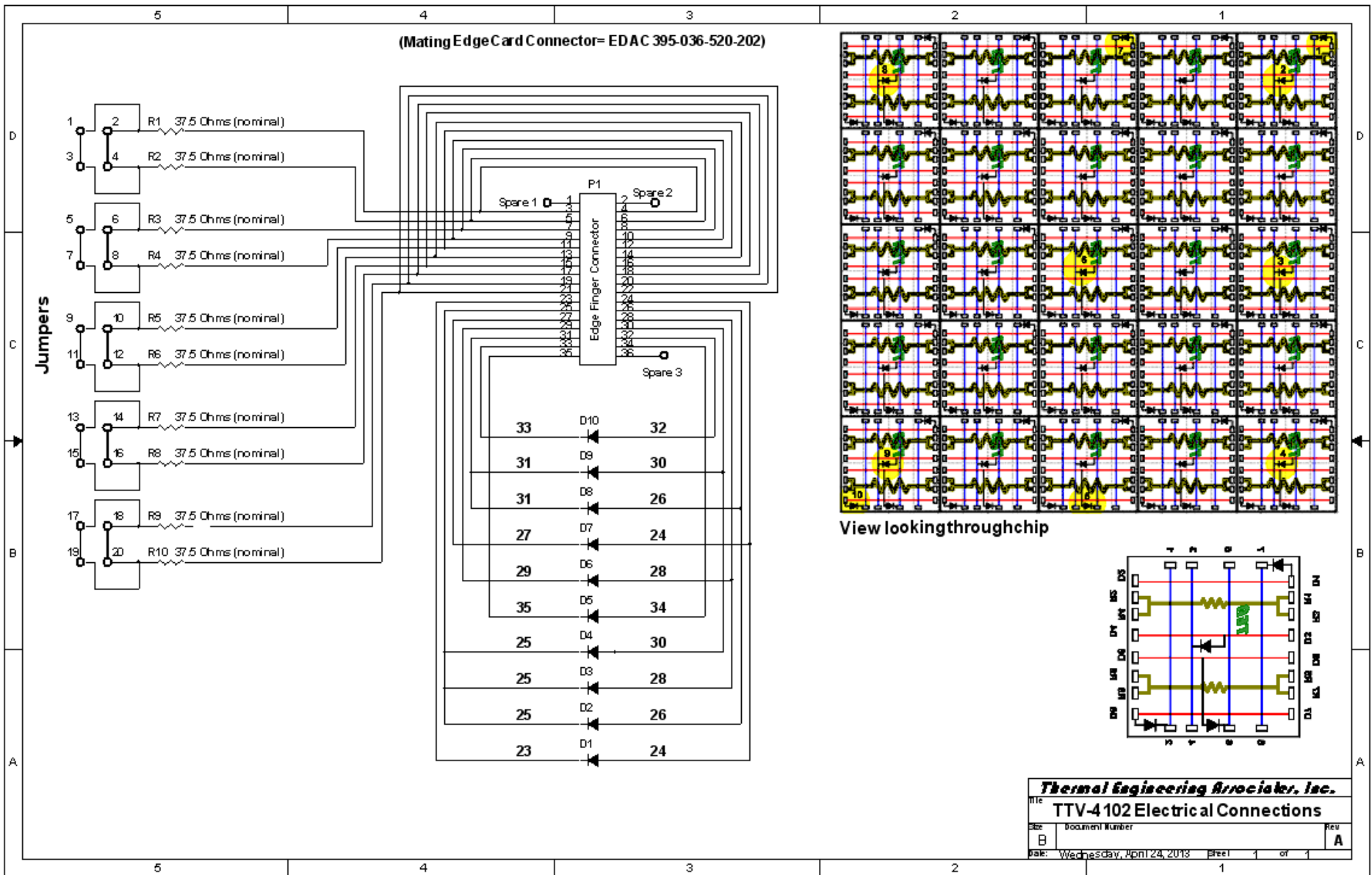

TTV-4101 Uniform Heating → High Resistance Configuration

Heating Resistance (Ohms)	Power Dissipation (Watts)	Heating Voltage (Volts)	Heating Current (Amps)
15	20	17.32	1.15
	40	24.49	1.63
	60	30.00	2.00
	80	34.64	2.31
	100	38.73	2.58
	120	42.43	2.83
	140	45.83	3.06
	160	48.99	3.27
	180		Voltages over 50V not recommended
	192		

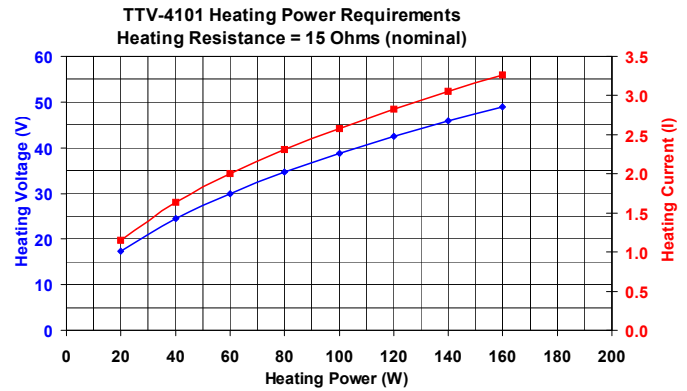

Junction Temperature limited to $\leq 150^{\circ}\text{C}$

TTV-4101 Uniform Heating → Low Resistance Configuration

Heating Resistance (Ohms)	Power Dissipation (Watts)	Heating Voltage (Volts)	Heating Current (Amps)
3.75	20	8.66	2.31
	40	12.25	3.27
	60	15.00	4.00
	80	17.32	4.62
	100	19.36	5.16
	120	21.21	5.66
	140	22.91	6.11
	160	24.49	6.53
	180	25.98	6.93
	192	26.83	7.16

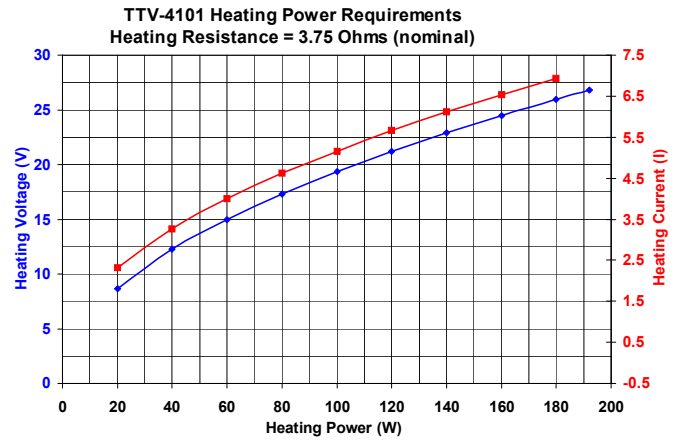

Junction Temperature limited to $\leq 150^{\circ}\text{C}$

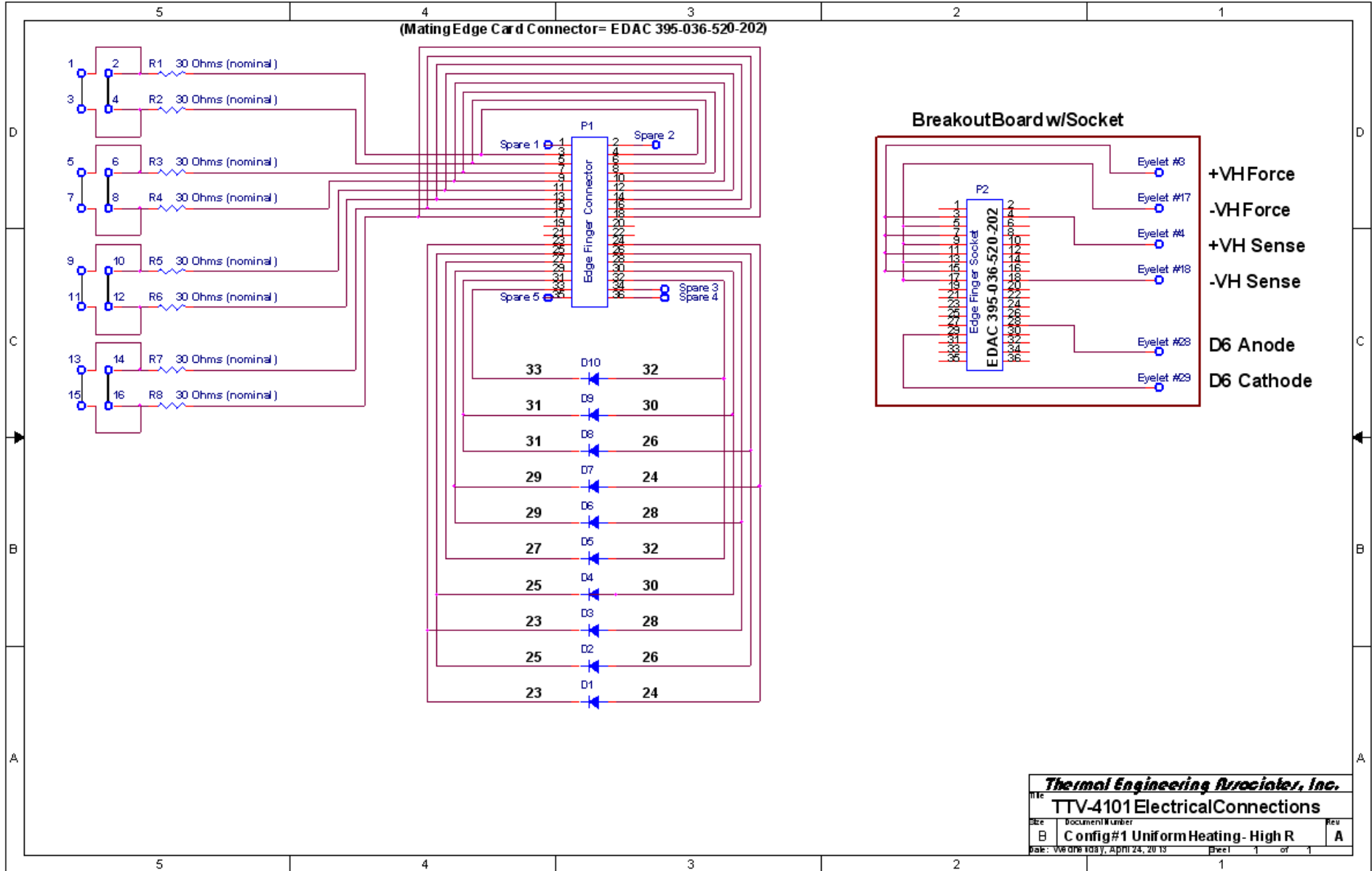

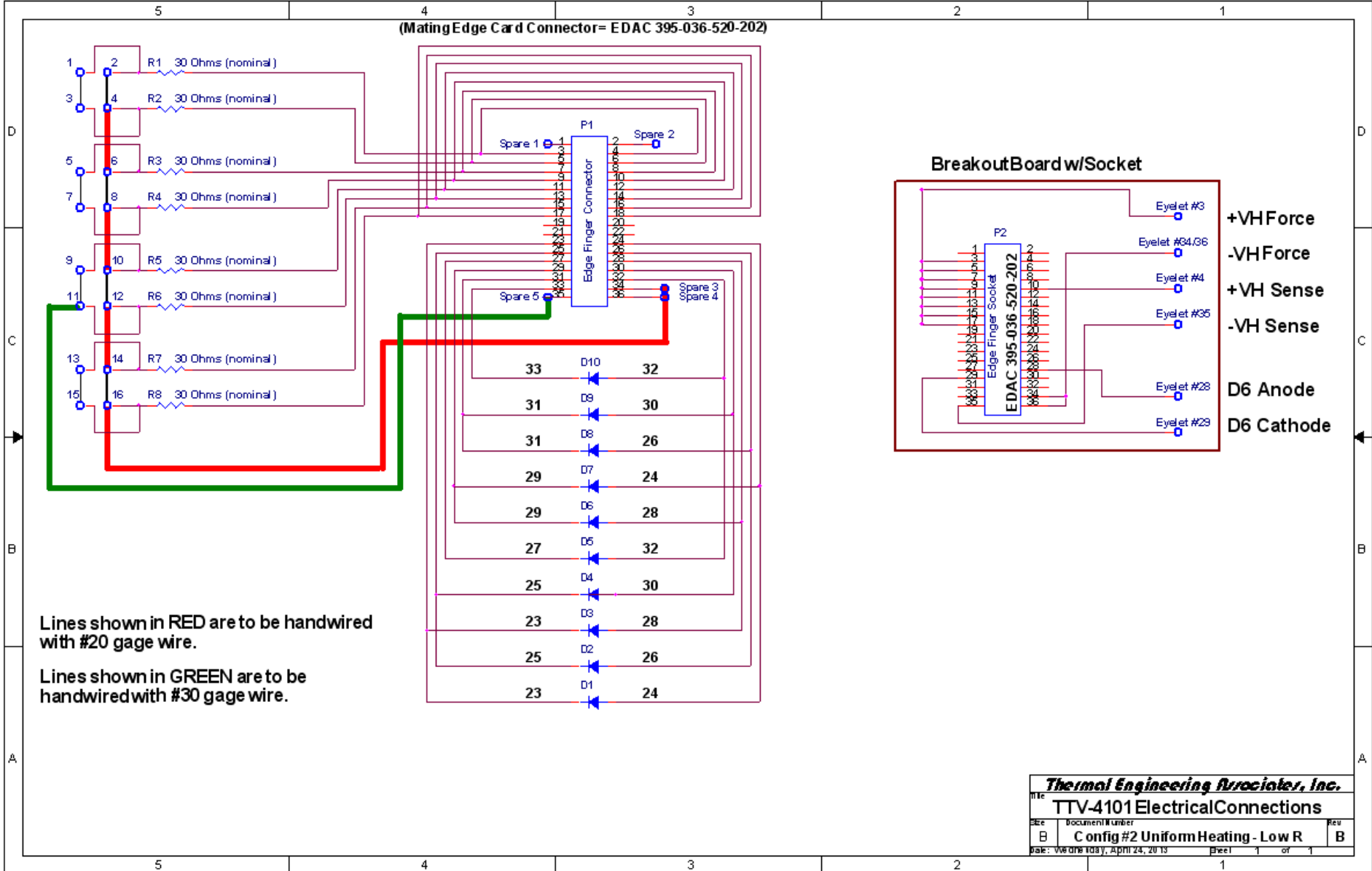

TTV-4102 Uniform Heating → High Resistance Configuration

Heating Resistance (Ohms)	Power Dissipation (Watts)	Heating Voltage (Volts)	Heating Current (Amps)
15	20	17.32	1.15
	40	24.49	1.63
	60	30.00	2.00
	80	34.64	2.31
	100	38.73	2.58
	120	42.43	2.83
	140	45.83	3.06
	160	48.99	3.27
	180	Voltages over 50V not recommended	
	200		
	220		
	240		
	260		
	280		
300			

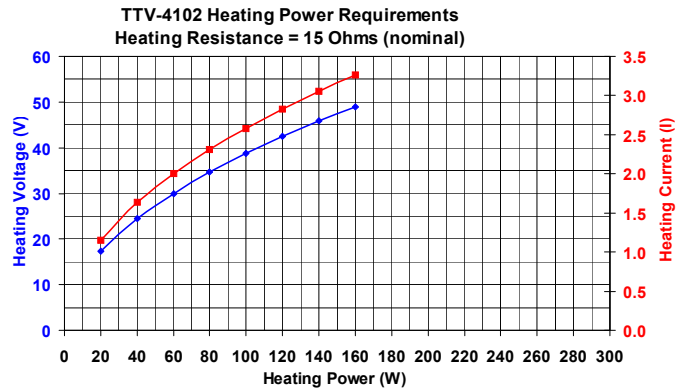

Junction Temperature limited to $\leq 150^{\circ}\text{C}$

TTV-4102 Uniform Heating → Low Resistance Configuration

Heating Resistance (Ohms)	Power Dissipation (Watts)	Heating Voltage (Volts)	Heating Current (Amps)
3.75	20	8.66	2.31
	40	12.25	3.27
	60	15.00	4.00
	80	17.32	4.62
	100	19.36	5.16
	120	21.21	5.66
	140	22.91	6.11
	160	24.49	6.53
	180	25.98	6.93
	200	27.39	7.30
	220	28.72	7.66
	240	30.00	8.00
	260	31.22	8.33
	280	32.40	8.64
300	33.54	8.94	

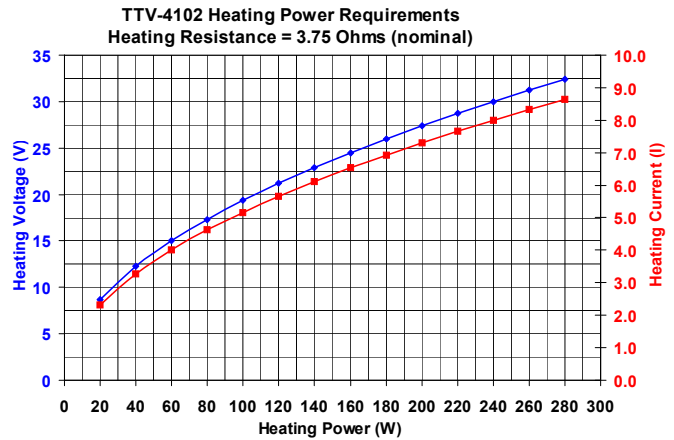

Junction Temperature limited to $\leq 150^{\circ}\text{C}$

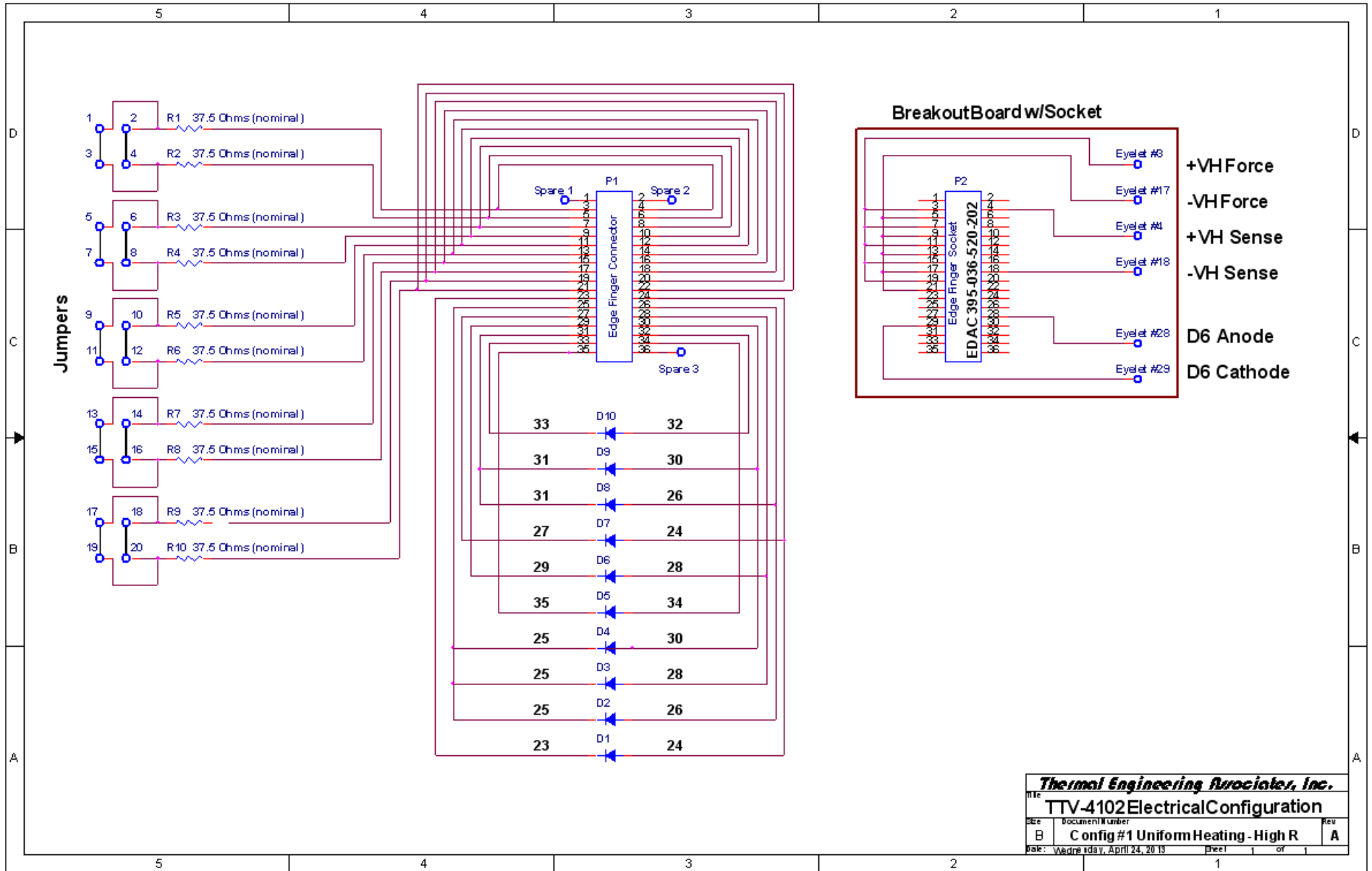

Thermal Engineering Associates, Inc.			
Title: TTV-4102 Electrical Configuration			
Size: B	Document Number: Config #1 Uniform Heating - High R	Rev: A	
Date: Wednesday, April 24, 2013		Sheet: 1	of 1

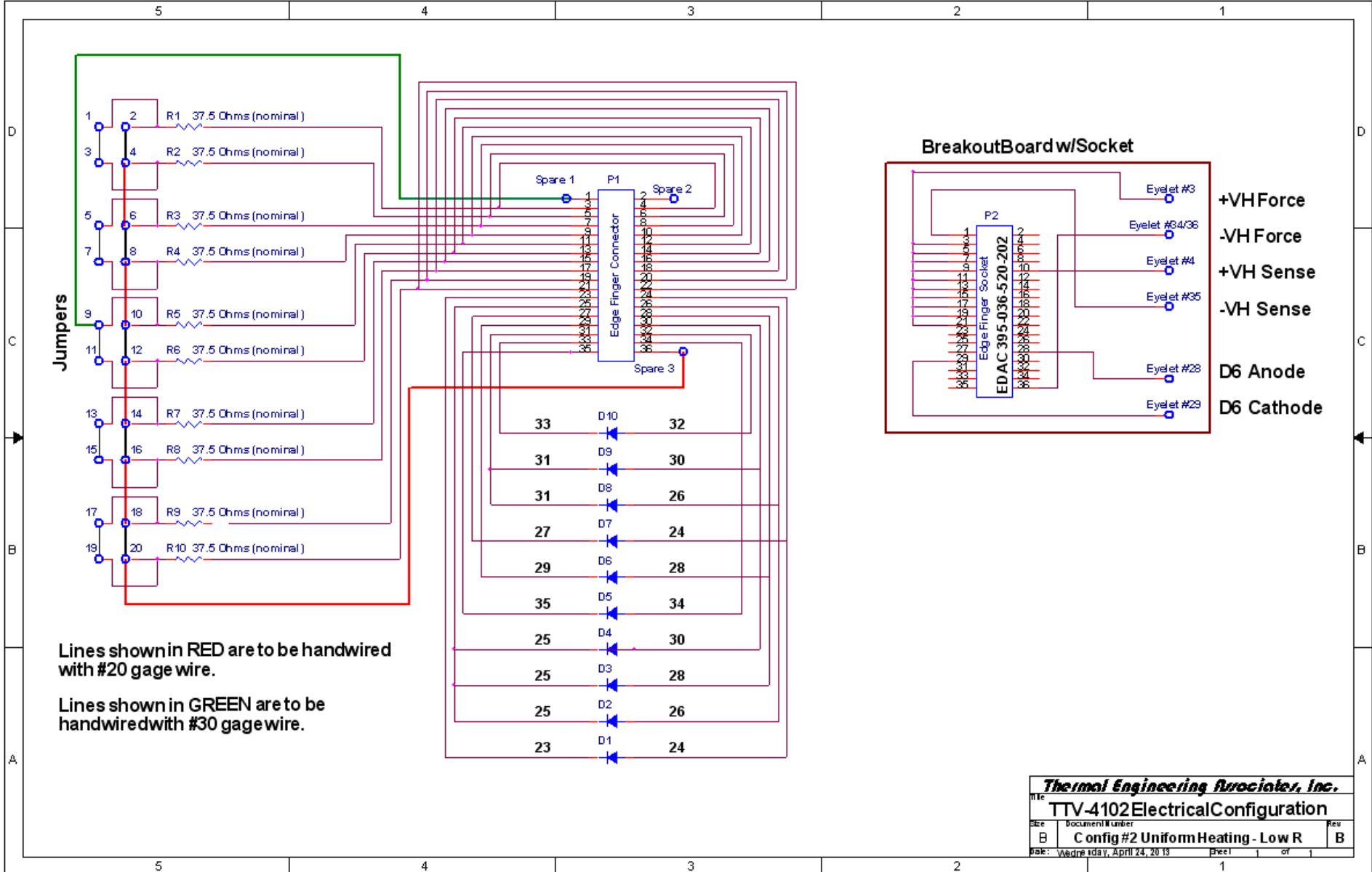

Application Guidelines

The TTC-1002 Thermal Test Chip mounted on the TTB-410X Thermal Test Board is a silicon chip that is relatively brittle. As such, the TTC must be handled with care – it can easily chip or fracture.

When applying a heat sink or cold plate to the top of Thermal Interface Material (TIM) sitting on the TTC surface, care should be taken to avoid dropping or non-parallel placement of the heat sink or cold plate directly onto the TIM. Examples of damage to the chip are shown below:

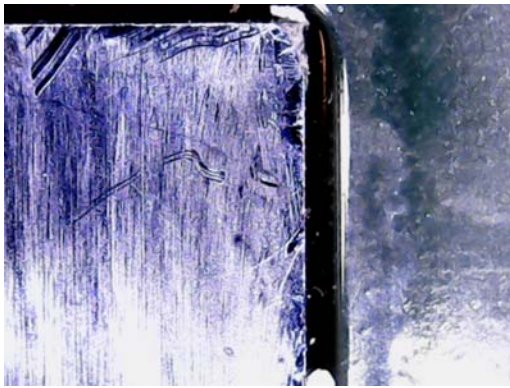

Example of chipped corner and surface scratched.

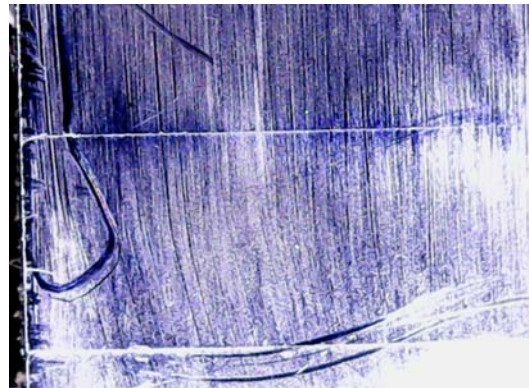

Example of fractured chip

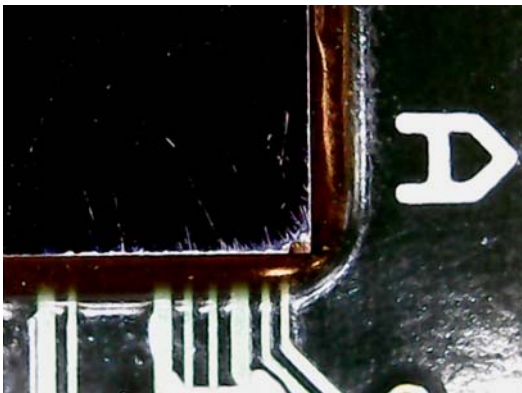

Example of chipped corner



Example of chipped corner and fracture starts

Vertical deflection of the TTB should be limited to no more than 0.004" (100 μ m) in either vertical direction. Further, the board should not be twisted along any axis. Either of these actions can disrupt the contact between the chip and the board, which will result in either a non-functional unit or one with unreliable performance. Fracturing of the chip can also occur.

The diagram below shows a typical TTV application configuration – various elements are:

1. Heat Sink or Cold Plate
2. TIM
3. TTC
4. TTB
5. Spacer
6. Backing Plate

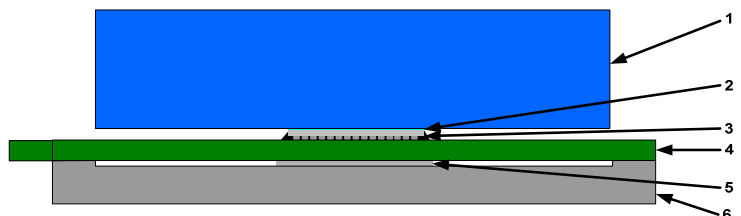

Items 3 and 4 comprise the TTV-410X product.

The Spacer (Item 5) is non-compressible material that is an electrical insulator and has very low thermal conductivity. The latter insures that nearly all (normally in the range of 99%) heat generated in the chip will propagate through the backside of the chip into the heat sink or cold plate. The Spacer material should be able to handle at least 130°C without increasing compressibility. An example of suitable spacer material is automotive head gasket material.

The Backing Plate material is typically stainless steel and is thick enough (~0.100" [2.54mm]) to insure the above stated deflection requirements. The plate cavity depth should be equal to the Spacer thickness. The cavity bottom surface and the plate mounting surface for the board should be as parallel as possible to make sure there is no tilt between the Spacer and the backside of the board.

When attaching the Thermal Management Solution (TMS), i.e. – TIM and heat sink or cold plate, to the assembly, it is important that attachment be to the Backing Plate, not to the TTV unit. The TTV unit should actually be guided in the X-Y direction by the attachment screws – the screws should pass through the board but not be attached to the board. Tightening of the screws for the TMS on the chip should be done in a sequential, rotating fashion so that the solution is applied parallel to the chip thermal interface surface. Typically this means that the screws in a four-screw configuration, as shown ay right, should be first finger-tight in a 1-3-2-4 sequence before applying the final screw torque.

If the TMS is mounted using a spring assembly, pressure should be applied to the TMS to make sure the TMS interface surface remains coplanar with the chip as each spring assembly (i.e. – spring and fastener) is put into position and secured to the backing plate.

All TTV-410X units have a solder mask on top and bottom of the board to insure that the traces are electrically insulated expect where electrical contact is supposed to be made – the edge finger contacts on one end and the user-implemented jumper area on the other end. The solder mask material is relatively thin and can be easily scrapped off by metal objects such as TMS edges, metal caps over the TTC, or tools used in mounting the TMS (including the Backing Plate). The user must be careful in the handling the TTV units to avoid damage to the solder mask, especially in the immediate vicinity around the TTC. An example of how to design a metal cap is shown at the right.

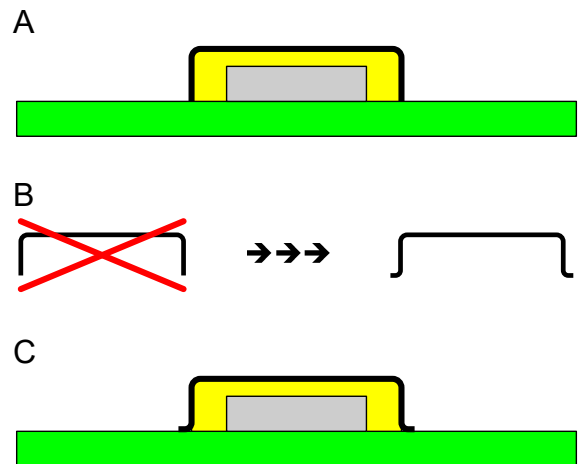

TEA can review customer TMS mounting designs upon request.

TEA inspects each TTV-410X unit before shipment to make sure the TTC has no chips or cracks and the solder mask is intact. Any returned units that exhibit such damage are considered to have user-induced damage and will not be considered for replacement by TEA.

Apparatus Setup for TTV-410X

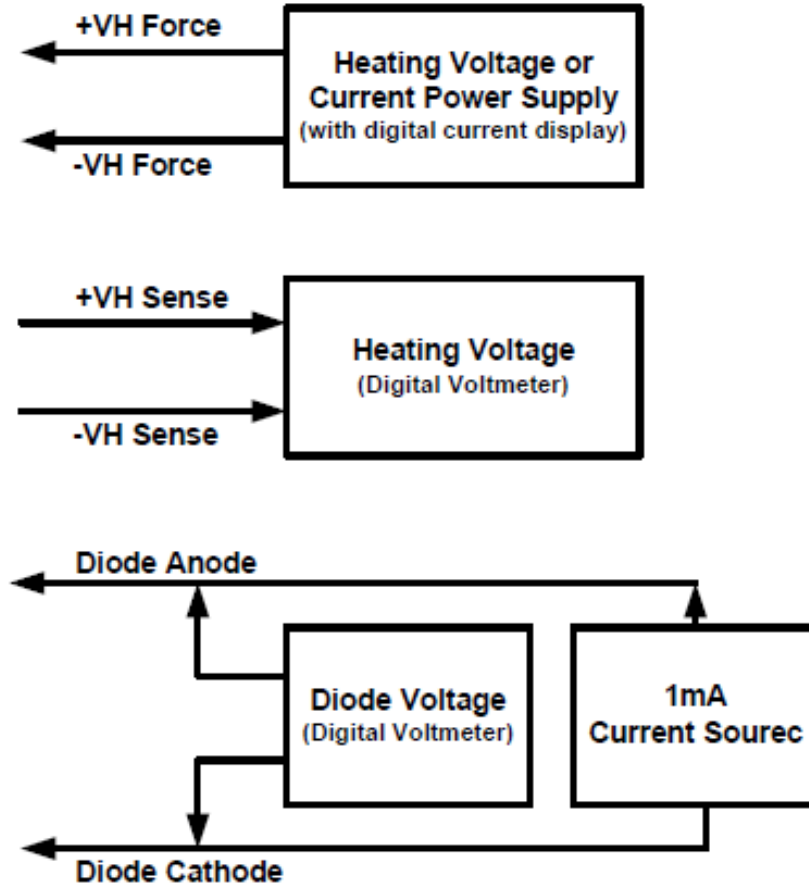

An example of a suitable current source design can be found in Tech Brief [TB-18 1mA Current Source Reference Design](#).

TEA also offers equipment to simplify the use of the TTV-410X products. Please see page 17.

Measurement Procedure (TIM Application-Oriented Thermal Resistance)

- 1) Mount the heat sink solution, including the TIM, on the TTV-410X unit.

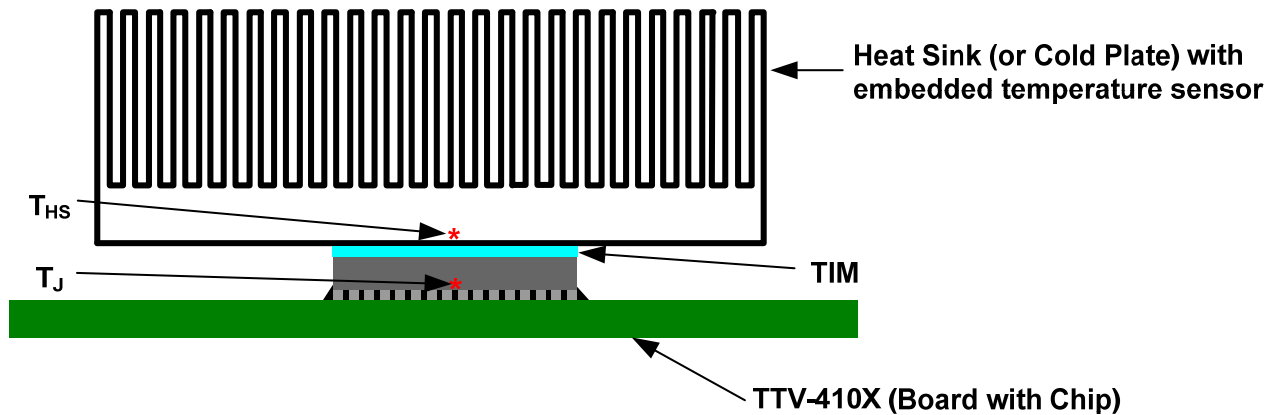

- 2) Connect up the power supply and measurement equipment shown in the Apparatus Setup.
- 3) Apply the 1.0mA Measurement Current to the diodes used for temperature measurement.
- 4) Wait for thermal equilibrium to occur - i.e., when the diode voltages stop changing - to record the diode voltage. Also record the Heat Sink temperature and the ambient temperature.
- 5) Apply power to the TTV Heating Resistors by setting the power supply to reach the desired power level.
- 6) Monitor the diode voltage with the 1.0mA current applied until a steady-state condition has occurred - i.e., when the diode voltages stop changing - to record the diode voltage.
- 7) Remove the power to the TTV Heating Resistors.
- 8) Calculate the Thermal resistance from Junction to Heat Sink as follows:

$$\Theta_{J-HS} = \left| \frac{(V_{Di} - V_{Df}) \times K}{P} \right|$$

where:

V_{Di} is from step 4

V_{Df} is from step 6

P is from step 5 recorded just before step 6 readings

K is the K Factor value - either the nominal value shown in the TTC Application Manual (http://www.thermengr.net/TTC/TTC_Manual_R7.pdf) or calibrated as described in the manual (see Chapter 3).

Heat Spreader Tables

Some thermal measurement applications require a heat source that is larger than currently available in the TTV-410X family. There are two ways to address these applications –

- Design and manufacture a new TTV-410X family product with a larger Thermal Test Chip (TTC) size. This approach is doable but not economic due to high implementation cost and low market demand.
- Use an existing TTV-410X product and integrate a Heat Spreader Table over the TTC. The HST is made out of Oxygen-Free Copper (OFC), has four mounting legs to sit over the TTC at a precise height, and is optionally available with an embedded temperature sensor (thermocouple or thermistor). The OFC is plated with 50µinch of hard Nickel to prevent copper oxidation and to provide scratch resistance. This approach is shown below.

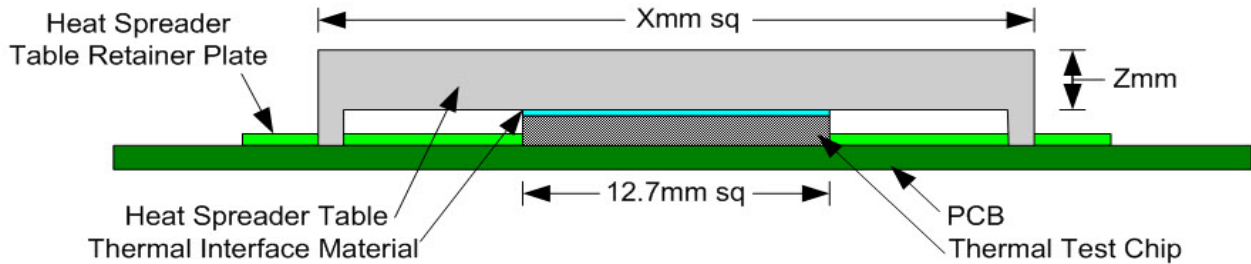

Standard X dimension are:

20mm	35mm	50mm
25mm	40mm	
30mm	45mm	

The 50mm version does not require the Retainer Plate. Custom X dimensions are also available.

The Z dimension varies according to the X dimension to provide a temperature variation across the HST top surface of less than 3°C. Custom Z dimensions are also available.

Embedded temperature sensors – either #40 Type-T thermocouple or a 0.20"Ø, 10KOhm thermistor – are optionally available. If the Z dimension is large enough (>2mm) and the X dimension is small enough (<25mm), then the sensor is inserted into a hole drilled into the HST side. Otherwise, the sensor is embedded into a slot milled into the table top or bottom surface of the table.

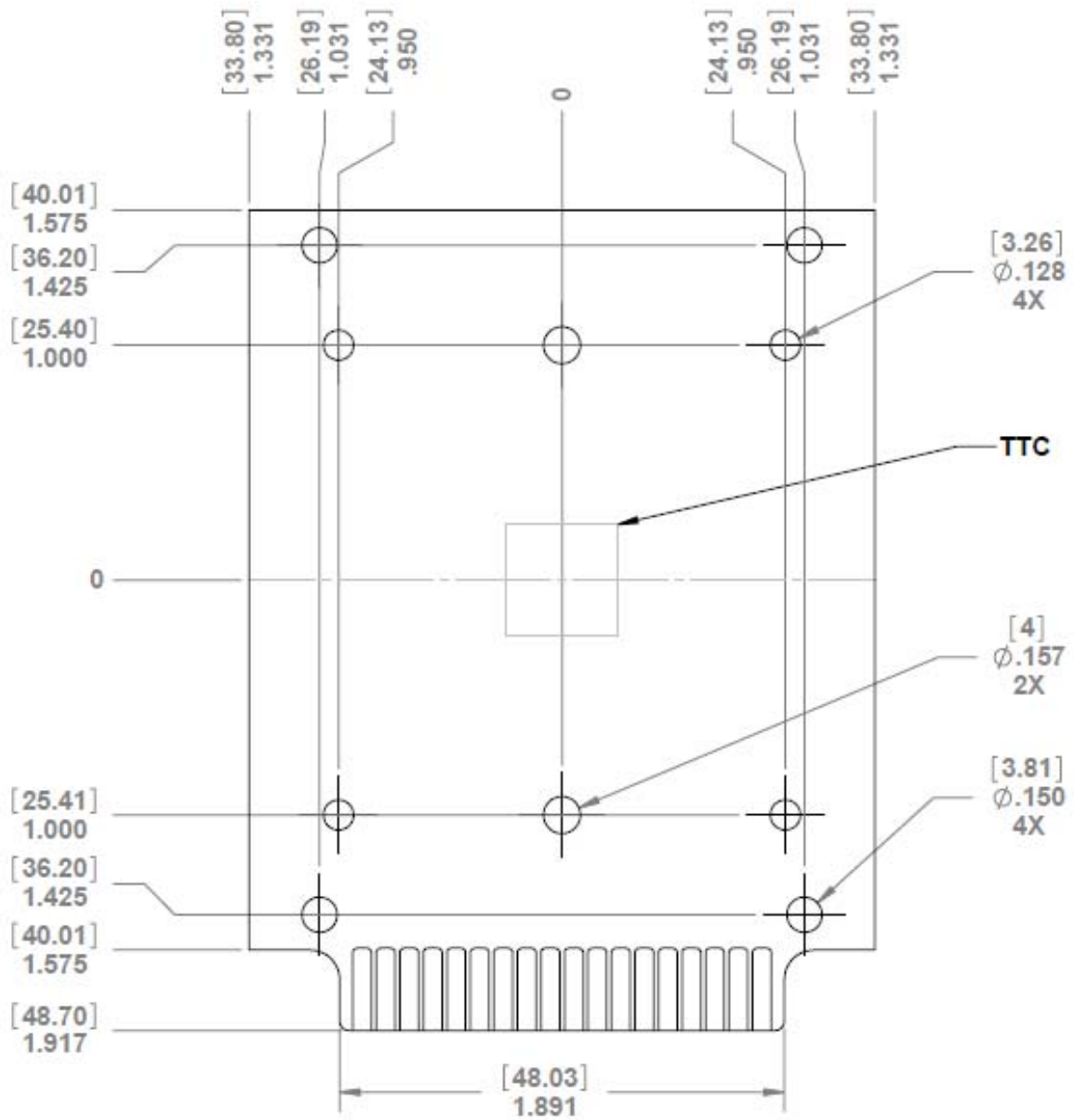

(Mating Edge Card Connector = EDAC 395-036-520-202)

Board Thickness = 0.063" (1.6mm)

DIMENSIONS ARE IN INCHES TOLERANCES: FRACTIONAL ± ANGULAR; MACH ± BEND ± TWO PLACE DECIMAL ± THREE PLACE DECIMAL ± MATERIAL FRESH DO NOT SCALE DRAWING	NAME B. Siegal	DATE 12/29/12	Thermal Engineering Associates SIZE DWG. NO. TTB-410X REV. SCALE: 1:1 DATE SHEET 1 OF 1
	CHECKED		
	ENG APPR.		
	MFG APPR.		
	Q.A.		
COMMENTS:			

TTV-410X Assemblies

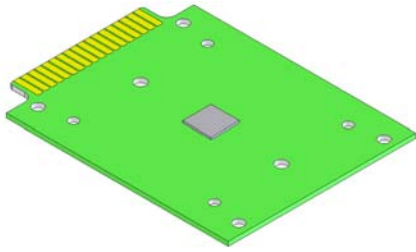

TTV-410X Basic Unit

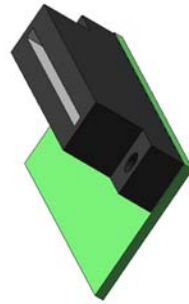

BreakOut Board
w/Connector

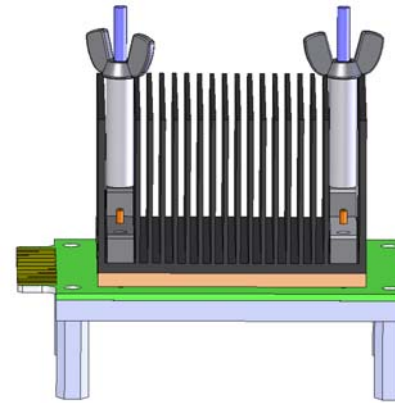

Low-Power
Heat Sink Assembly

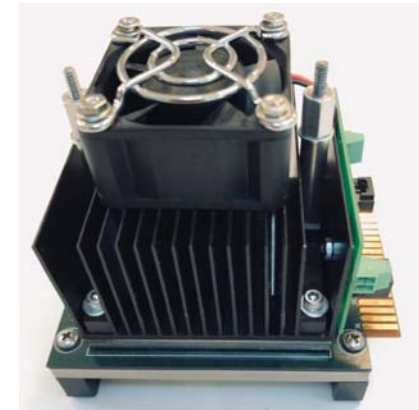

High-Power
Heat Sink Assembly

		Product Class	Array Size		Break Out Board		Heat Sink Config		Temp Sensor Config
TTV	-	41	00	-	0	-	00		0

41 Defines the Product Class

- 1 4X4 Array (10.23mmX10.23mm) TTC
- 2 5X5 Array (12.8mmX12.8mm) TTC
- 0X No TTV board, use for specifying BOB and/or Heat Sink options only

- 0 None
 - 1 BOB w/105°C Connector
 - 2 BOB w/130°C Connector
 - 3 BOB w/105°C Connector, diode ribbon cable connector
- BOB => BreakOut Board

- 00 Board & Chip only (No Heat Sink Assembly)
- 10 Lo-Pwr Heat Sink Assembly
- 20 Hi-Pwr Heat Sink Assembly (includes 12V fan)

- 0 No embedded Temp Sensor
- 1 Embedded Type-T Thermocouple Temp Sensor
- 2 Embedded 10KΩ NTC Thermistor Temp Sensor

TTV-410X Measurement Equipment

To simplify the use of the TTV-410X products, TEA offers the following equipment:

1mA Constant Current Source

This is a hand-held unit that can operate from an internal 9V battery or a supplied wall-mounted power supply connected to a 100 -230VAC Power Main. The integrated 3½-digit display provides 1mV resolution. Connection is via standard banana jacks at the base of the unit.

This product is based on the circuitry shown in Tech Brief [TB-18 1mA Current Source Reference Design](#).



TMM-100 Temperature Measurement Module

The TMM-100 is designed to simplify the gathering of temperature data from eight Thermal Test Chip diode temperature sensors. The system contains precision current sources for supplying diode measurement current (I_M), voltmeter capability for diode measurement (V_M), and Type-T thermocouple and 10K Ω NTC thermistor measurement capability for monitoring the environment temperature. Front-panel mounted connectors provides for up to eight temperature sensing diodes, two thermocouples and two thermistors. All temperature sensor channels can individually be enabled or disabled using simple commands.

For any of the selected eight diode temperature sensing channels, the internal precision I_M current source provides 1.00mA with a voltage compliance of 2V. The internal voltage measurement circuit measures to 1.999V with 1mV resolution. The temperature measurement resolution of 0.1°C for all sensors provides for accurate temperature differential measurements.

The TMM is powered through its USB connection to a computer, so no external power supply is required.

The figure on the next page shows a typical thermal resistance measurement setup using the TTV-410X and the TMM-100.

For further information, the user manual can be downloaded from http://www.thermengr.net/Lit/TMM-100_User_Manual.pdf.



Thermal Resistance Measurement Setup (implemented in TMS-5000 Thermal Measurement System)

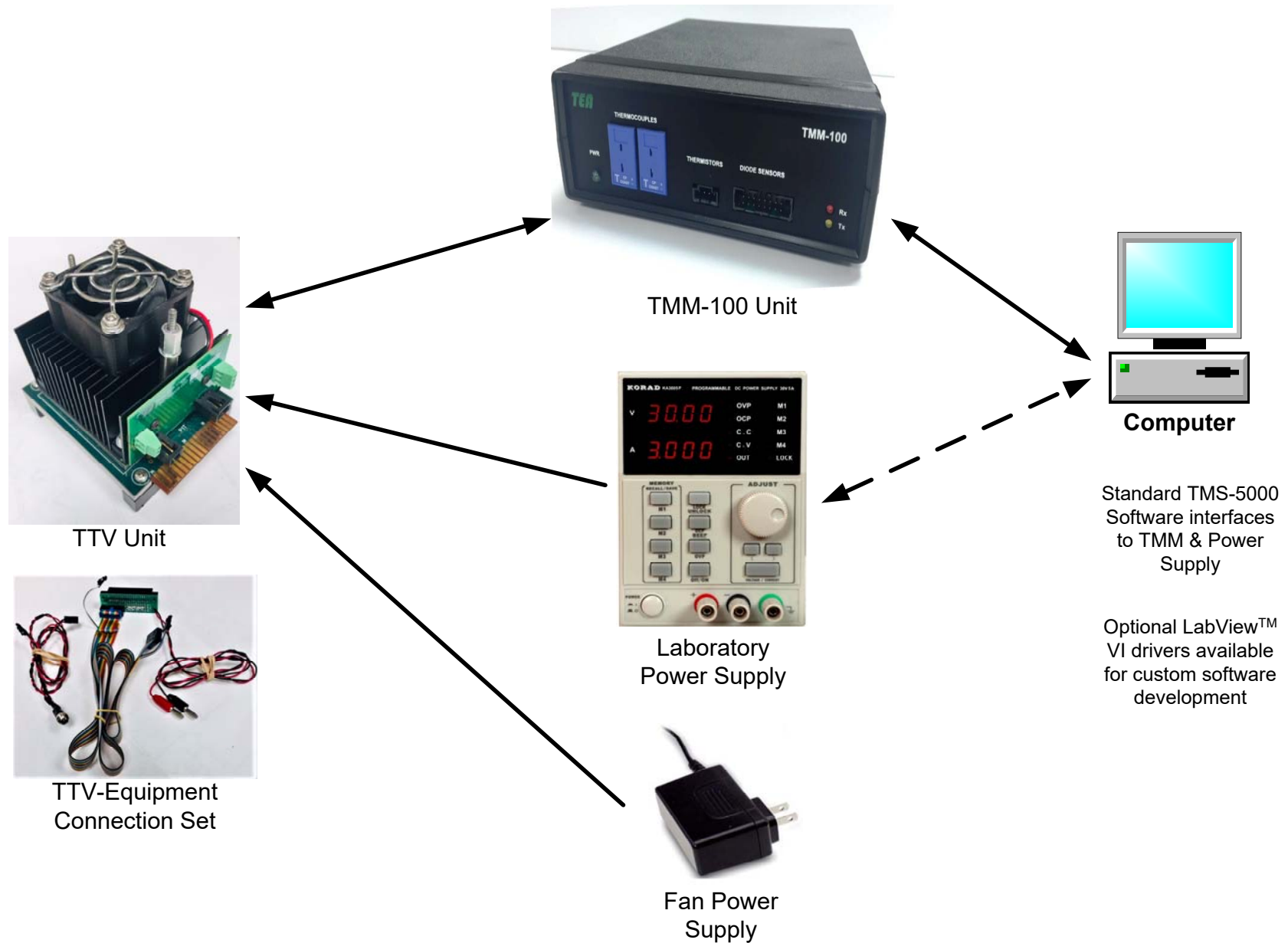

For further information, the user manual can be downloaded from https://www.thermengr.net/Lit/TMS-5000_User_Manual.pdf